

BD50F

Direct Current Compressor

R134a

12 - 24V

Data Sheet (Replaces CD.46.B3.02)

General

Compressor	BD50F
Code number: Comp. without electronic unit	101Z1220
Code number: Electronic unit 12-24V DC	single: 101N0210, 30 pcs: 101N0211

Application

Application	LBP/MBP/(HBP)
Evaporating temperature range °C	-30 to 0 (10)
Voltage range / max. voltage	12 - 24V DC / 31.5V DC
Max. machine compartment temperature °C	55
Comp. cooling at ambient temp. 43°C	S or F ₁ *

Design

* depending on application

Displacement	cm ³	2.50
Oil quantity	cm ³	150
Maximum refrigerant charge	g	300
Free gas vol. in compressor	cm ³	870
Weight: Compressor/Electronic unit	kg	4.3/0.25

Motor

Motor type	Variable speed	
Resistance, all 3 windings (25°C)	Ω	2.0
Approvals (electronic unit)	E4 72/245 95/54 0277 00	

Dimensions

Height	mm	A	137
		B	135
		B1	128
		B2	73
Suction connector	location/I.D. mm	C	6.2 ±0.09
Process connector	location/I.D. mm	D	6.2 ±0.09
Discharge connector	location/I.D. mm	E	5.0 +0.12/+0.20
Compressors on a pallet	pcs.		120

Standard battery protection settings

12V cut-out [V]	12V cut-in [V]	24V cut-out [V]	24V cut - in [V]
10.4	11.7	22.8	24.2

Optional battery protection settings

Resistor (R2) [kΩ]	12V cut-out [V]	12V cut-in [V]	12V max. Voltage	24V cut-out [V]	24V cut-in [V]	24V max. Voltage
0	9.6	10.9	17.0	21.3	22.7	31.5
1.6	9.7	11.0	17.0	21.5	22.9	31.5
2.4	9.9	11.1	17.0	21.8	23.2	31.5
3.6	10.0	11.3	17.0	22.0	23.4	31.5
4.7	10.1	11.4	17.0	22.3	23.7	31.5
6.2	10.2	11.5	17.0	22.5	23.9	31.5
8.2	10.4	11.7	17.0	22.8	24.2	31.5
11	10.5	11.8	17.0	23.0	24.5	31.5
14	10.6	11.9	17.0	23.3	24.7	31.5
18	10.8	12.0	17.0	23.6	25.0	31.5
24	10.9	12.2	17.0	23.8	25.2	31.5
33	11.0	12.3	17.0	24.1	25.5	31.5
47	11.1	12.4	17.0	24.3	25.7	31.5
82	11.3	12.5	17.0	24.6	26.0	31.5
220	9.6	10.9				31.5

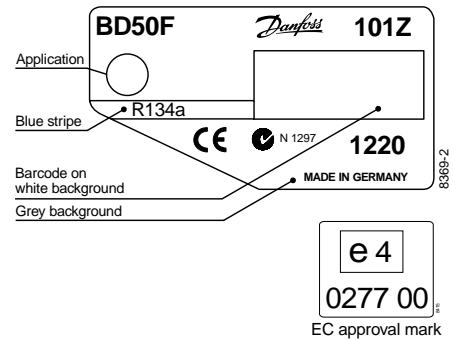

- S = Static cooling normally sufficient
- O = Oil cooling
- F₁ = Fan cooling 1.5 m/s
(compressor compartment temperature equal to ambient temperature)
- F₂ = Fan cooling 3.0 m/s necessary

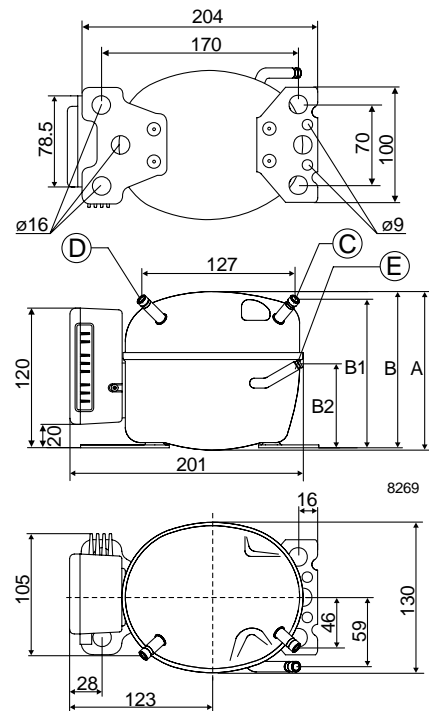

Capacity (EN 12900/CECOMAF)

watt

rpm \ °C	-30	-25	-23.3	-20	-15	-10	-5	0	5	10
2,000	20.1	31.0	34.9	42.8	56.3	72.2	91.6	115	144*	178*
2,500	27.0	39.0	43.4	52.7	68.9	88.9	113	144*	181*	
3,000	31.0	45.4	50.6	61.5	80.7	104	134*	171*		
3,500	38.1	53.2	59.1	71.9	95.0	124*	159*			

Capacity (ASHRAE)

watt

rpm \ °C	-30	-25	-23.3	-20	-15	-10	-5	0	5	10
2,000	24.7	38.3	43.1	52.9	69.5	89.3	113	143	178*	221*
2,500	33.3	48.1	53.6	65.0	85.1	110	140	178*	224*	
3,000	38.2	56.0	62.5	75.9	100	129	166*	212*		
3,500	47.0	65.7	72.9	88.7	117	153*	196*			

Power consumption

watt

rpm \ °C	-30	-25	-23.3	-20	-15	-10	-5	0	5	10
2,000	25.1	31.8	34.0	38.2	44.7	51.3	58.3	65.8	74.2*	83.5*
2,500	34.1	40.5	42.9	47.8	55.8	64.7	74.3	84.8*	96.1*	
3,000	39.9	49.2	52.2	57.8	66.5	76.4	88.4*	104*		
3,500	50.2	59.3	62.5	69.0	80.2	93.4*	109*			

Current consumption (for 24V applications the following must be halved)

A

rpm \ °C	-30	-25	-23.3	-20	-15	-10	-5	0	5	10
2,000	2.2	2.6	2.8	3.1	3.8	4.4	5.1	5.8	6.4*	6.9*
2,500	2.9	3.4	3.6	4.0	4.7	5.4	6.2	7.0*	7.8*	
3,000	3.5	4.2	4.4	4.9	5.6	6.5	7.4*	8.5*		
3,500	4.2	4.9	5.2	5.8	6.7	7.8*	9.0*			

COP (EN 12900/CECOMAF)

W/W

rpm \ °C	-30	-25	-23.3	-20	-15	-10	-5	0	5	10
2,000	0.80	0.98	1.03	1.12	1.26	1.41	1.57	1.75	1.94*	2.13*
2,500	0.79	0.96	1.01	1.10	1.24	1.37	1.53	1.70*	1.88*	
3,000	0.78	0.92	0.97	1.06	1.21	1.37	1.51*	1.65*		
3,500	0.76	0.90	0.95	1.04	1.19	1.32*	1.45*			

COP (ASHRAE)

W/W

rpm \ °C	-30	-25	-23.3	-20	-15	-10	-5	0	5	10
2,000	0.99	1.21	1.27	1.38	1.56	1.74	1.94	2.16	2.40*	2.65*
2,500	0.98	1.19	1.25	1.36	1.53	1.70	1.89	2.10*	2.33*	
3,000	0.96	1.14	1.20	1.31	1.50	1.69	1.87*	2.04*		
3,500	0.94	1.11	1.17	1.28	1.46	1.64*	1.80*			

Test conditions EN 12900/CECOMAF ASHRAE
 Condensing temperature 55°C 55°C
 Ambient and suction gas temp. 32°C 32°C
 Liquid temperature 55°C 32°C
 Static cooling, 12V DC

* Fan cooling of electronic unit compulsory
 1 Watt = 0.86 kcal/h

Accessories

Devices	BD50F
Standard automobile fuse DIN 7258 12V: 15A 24V: 7.5A	Not deliverable from Danfoss
Mounting accessories Bolt joint for one compressor Bolt joint in quantities Snap on in quantities	118-1917 118-1918 118-1919

Compressor speed

Resistor (R1) [Ω]	Motor speed [rpm]	Control circ. Current [mA]
0	2,000	5
277	2,500	4
692	3,000	3
1523	3,500	2

Wire dimensions

Cross section [mm²]	Max. length ^{*)} [m]	
	12V operation	24V operation
2.5	2.5	5
4	4	8
6	6	12
10	10	20

^{*)} Length between battery and electronic unit

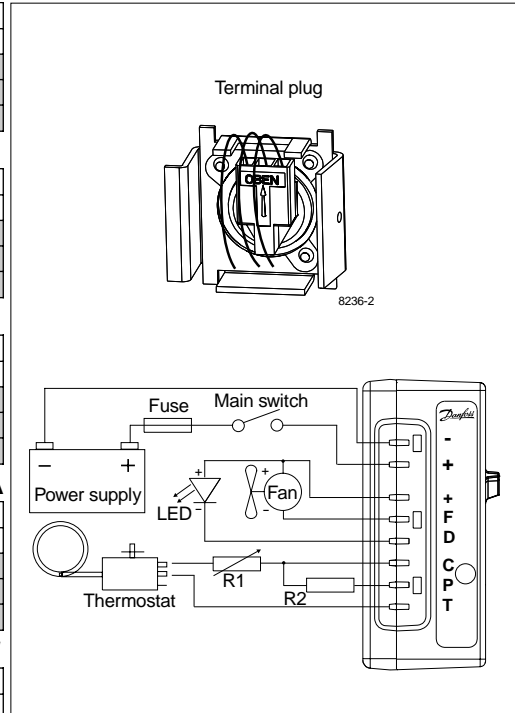

Operational errors shown by LED (optional)

Number of flashes	Error type
5	Thermal cut-out of electronic unit (If the refrigeration system has been too heavily loaded, or if the ambient temperature is high, the electronic unit will run too hot).
4	Minimum motor speed error (If the refrigeration system is too heavily loaded, the motor cannot maintain minimum speed at approximately 1,850 rpm).
3	Motor start error (The rotor is blocked or the differential pressure in the refrigeration system is too high (>5 bar)).
2	Fan over-current cut-out (The fan loads the electronic unit with more than 1A _{peak}).
1	Battery protection cut-out (The voltage is outside the cut-out setting).