

ITEM NO.	PART NUMBER	DESCRIPTION	QTY.
1	082-0026	17 x 20 Composite FRP/VIP Panel	3
2	082-0027	14.25 x 17 Composite FRP/VIP Panel	2
3	082-0024	17 x 20 Composite FRP/VIP Panel with medium hatch cut out	1
4	500-0200	RPARTS MEDIUM HATCH	1

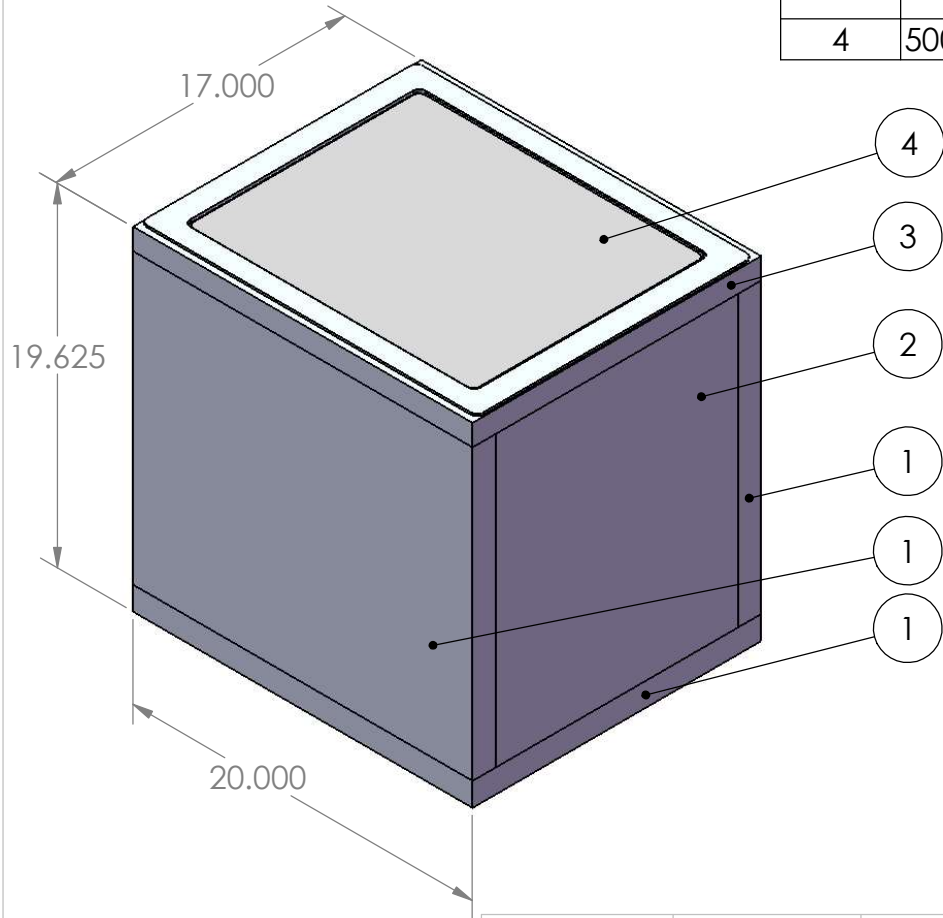

		UNLESS OTHERWISE SPECIFIED:	NAME	DATE	<b>RPARTS.COM</b>	
		DIMENSIONS ARE IN INCHES TOLERANCES: FRACTIONAL ± ANGULAR: MACH ± BEND ± TWO PLACE DECIMAL ± THREE PLACE DECIMAL ±	DRAWN			
		INTERPRET GEOMETRIC TOLERANCING PER:	CHECKED		<b>Ice Box Kit 2.4 cu. ft.</b>	
		MATERIAL	ENG APPR.			
		FINISH	MFG APPR.		SIZE	DWG. NO.
NEXT ASSY	USED ON		Q.A.		<b>A</b>	<b>011-0001</b>
APPLICATION		DO NOT SCALE DRAWING	COMMENTS:		REV	<b>2</b>
					SCALE: 1:8	WEIGHT:
					SHEET 1 OF 3	

**PROPRIETARY AND CONFIDENTIAL**  
 THE INFORMATION CONTAINED IN THIS DRAWING IS THE SOLE PROPERTY OF <INSERT COMPANY NAME HERE>. ANY REPRODUCTION IN PART OR AS A WHOLE WITHOUT THE WRITTEN PERMISSION OF <INSERT COMPANY NAME HERE> IS PROHIBITED.

ITEM NO.	PART NUMBER	DESCRIPTION	QTY.
1	082-0026	17 x 20 Composite FRP/VIP Panel	3
2	082-0027	14.25 x 17 Composite FRP/VIP Panel	2
3	082-0024	17 x 20 Composite FRP/VIP Panel with medium hatch cut out	1
4	500-0200	RPARTS MEDIUM HATCH	1

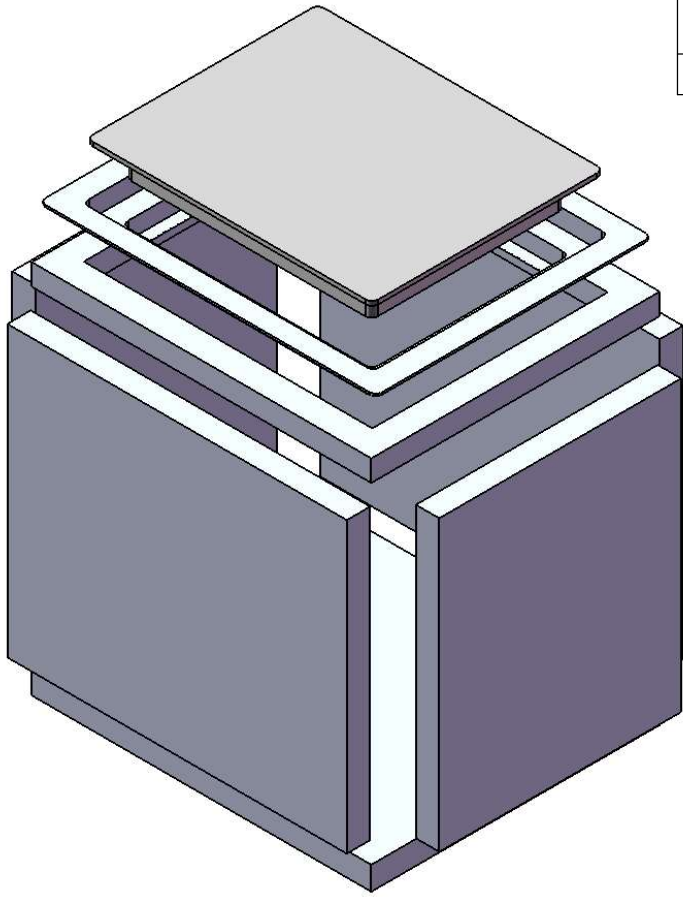

**PROPRIETARY AND CONFIDENTIAL**  
 THE INFORMATION CONTAINED IN THIS DRAWING IS THE SOLE PROPERTY OF <INSERT COMPANY NAME HERE>. ANY REPRODUCTION IN PART OR AS A WHOLE WITHOUT THE WRITTEN PERMISSION OF <INSERT COMPANY NAME HERE> IS PROHIBITED.

		UNLESS OTHERWISE SPECIFIED:	NAME	DATE	<b>RPARTS.COM</b>	
		DIMENSIONS ARE IN INCHES TOLERANCES: FRACTIONAL ± ANGULAR: MACH ± BEND ± TWO PLACE DECIMAL ± THREE PLACE DECIMAL ±	DRAWN			
		INTERPRET GEOMETRIC TOLERANCING PER:	CHECKED		<b>Ice Box Kit 2.4 cu. ft.</b>	
		MATERIAL	ENG APPR.			
		FINISH	MFG APPR.		SIZE	DWG. NO.
NEXT ASSY	USED ON		Q.A.		<b>A</b>	<b>011-0001</b>
APPLICATION		DO NOT SCALE DRAWING	COMMENTS:		REV	<b>2</b>
					SCALE: 1:8	WEIGHT:
					SHEET 2 OF 3	

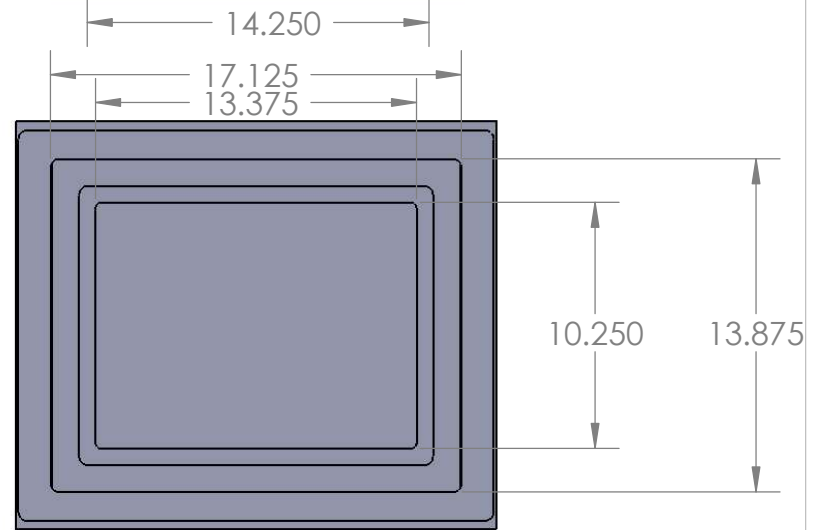
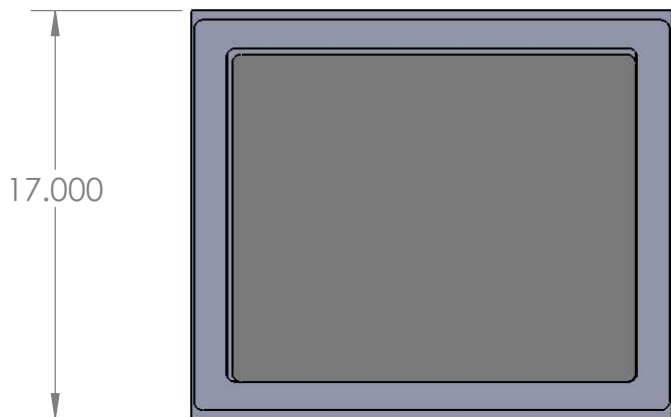
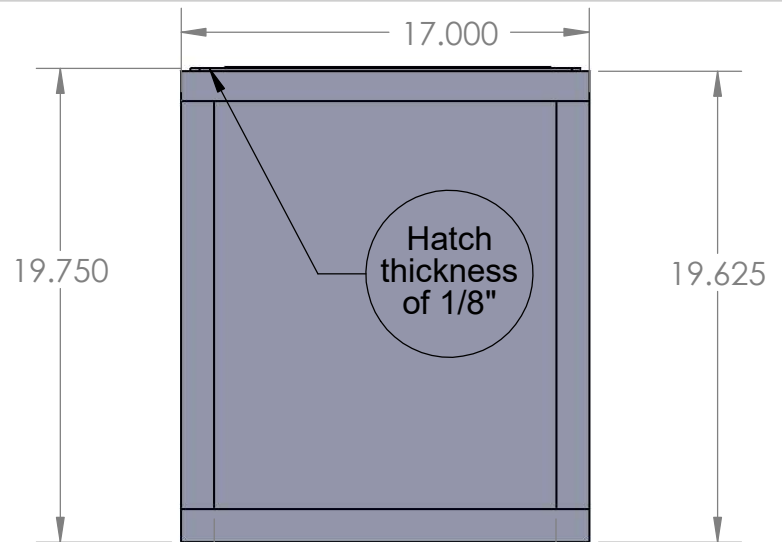
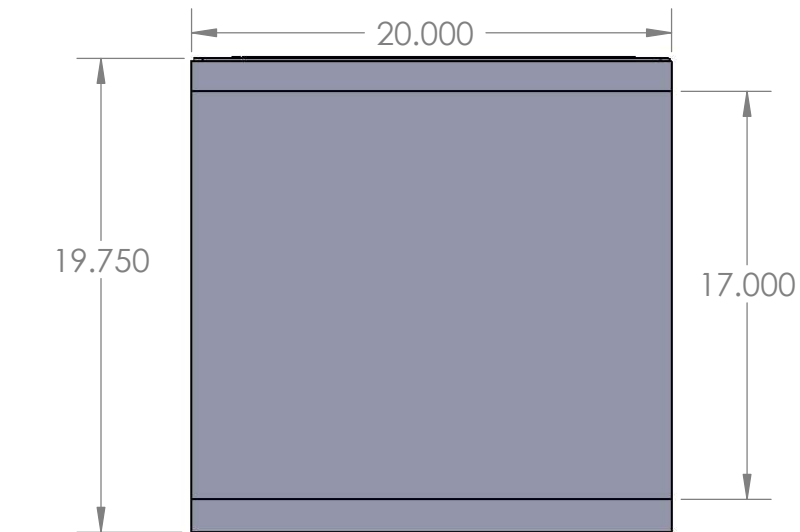

**PROPRIETARY AND CONFIDENTIAL**  
 THE INFORMATION CONTAINED IN THIS DRAWING IS THE SOLE PROPERTY OF <INSERT COMPANY NAME HERE>. ANY REPRODUCTION IN PART OR AS A WHOLE WITHOUT THE WRITTEN PERMISSION OF <INSERT COMPANY NAME HERE> IS PROHIBITED.

		UNLESS OTHERWISE SPECIFIED:	NAME	DATE
		DIMENSIONS ARE IN INCHES	DRAWN	
		TOLERANCES:	CHECKED	
		FRACTIONAL ±	ENG APPR.	
		ANGULAR: MACH ± BEND ±	MFG APPR.	
		TWO PLACE DECIMAL ±	Q.A.	
		THREE PLACE DECIMAL ±	COMMENTS:	
		INTERPRET GEOMETRIC TOLERANCING PER:		
		MATERIAL		
NEXT ASSY	USED ON	FINISH		
APPLICATION		DO NOT SCALE DRAWING		

<b>RPARTS.COM</b>		
TITLE:		
<b>Ice Box Kit 2.4 cu. ft.</b>		
SIZE	DWG. NO.	REV
<b>A</b>	<b>011-0001</b>	<b>2</b>
SCALE: 1:8	WEIGHT:	SHEET 3 OF 3

5

4

3

2

1